

Communication Interface Module Replacement

Removal Procedure

Note: The vehicle communication interface module (VCIM) has a specific set of unique numbers that tie the module to each vehicle. These numbers, the 10-digit station identification and the 11-digit electronic serial number, are used by the National Cellular Network and OnStar® to identify the specific vehicle. Because these numbers are tied to the vehicle identification number of the vehicle, you must never exchange these parts with those of another vehicle.

1. Position the right rear seat bottom to a cargo position.

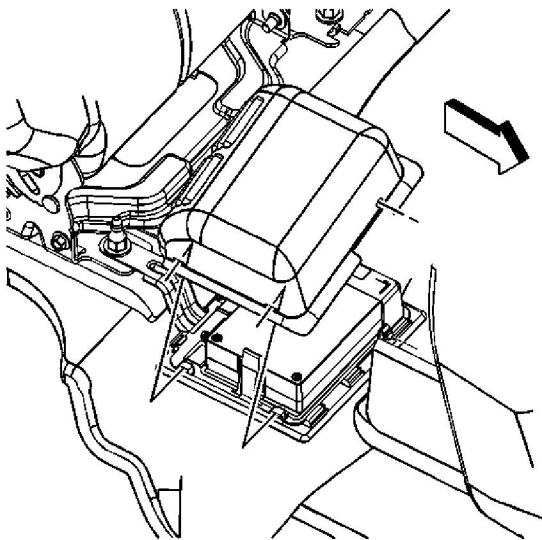

2. Remove the protective cover from the VCIM.

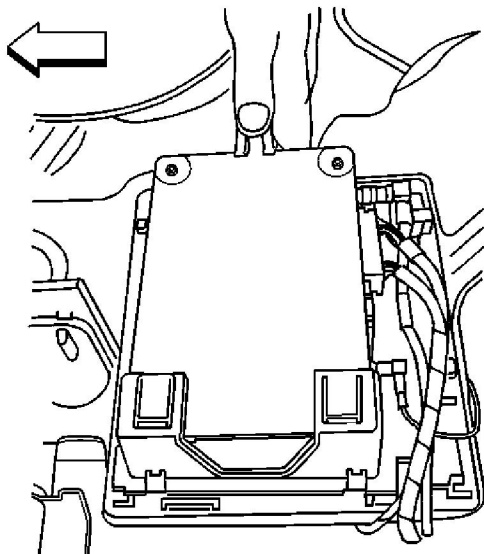

© 2012 General Motors Corporation. All rights reserved.



3. Remove the module from the upper bracket by releasing the retaining tab.

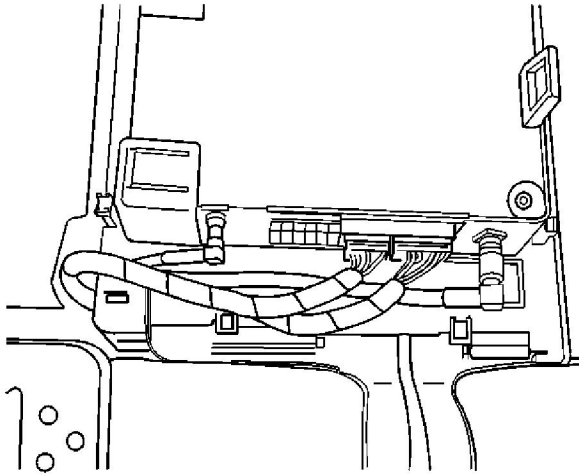

4. Remove the electrical connectors from the VCIM.
5. Remove the VCIM from the vehicle

Installation Procedure

1. If replacing the VCIM, record the 10-digit STID number, and the 11-digit ESN number from the labels on the new module.

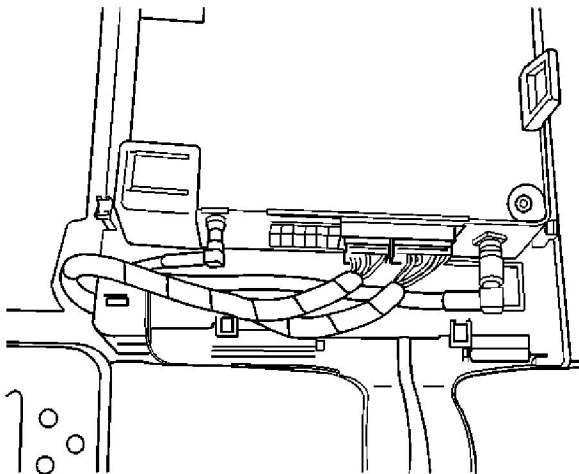

2. Install the module to the upper bracket ensuring the retaining tab is fully seated.

Caution: In order to avoid damage to the circuit board, do NOT over-tighten the thumb screws. Using your fingers, apply only a light pressure.

3. Connect the 2 electrical connectors. Tighten the module thumb screw to a maximum of **0.2 N·m (2 lb in)**.

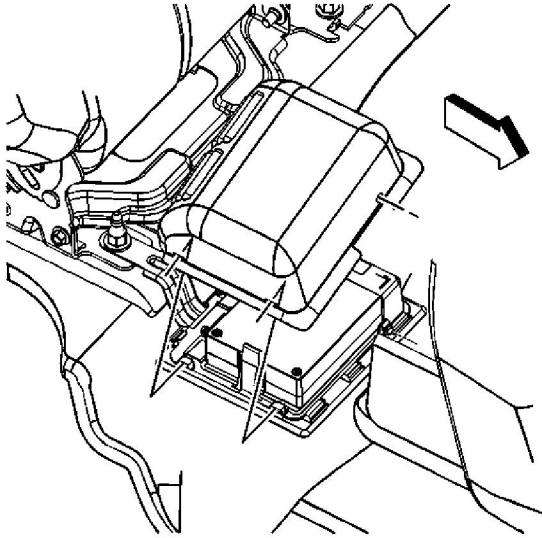

4. Install the protective cover to the module.
5. Position the right rear seat bottom to a passenger position.

Note: After replacing the vehicle communication interface module, you must reconfigure the OnStar® system. Failure to reconfigure the system will result in an additional customer visit for repair. In addition, pressing and holding the white dot button on the keypad will NOT reset this version of the OnStar® system. This action will cause a DTC to set.

6. For Programming and set up, Refer to [Control Module References](#).